

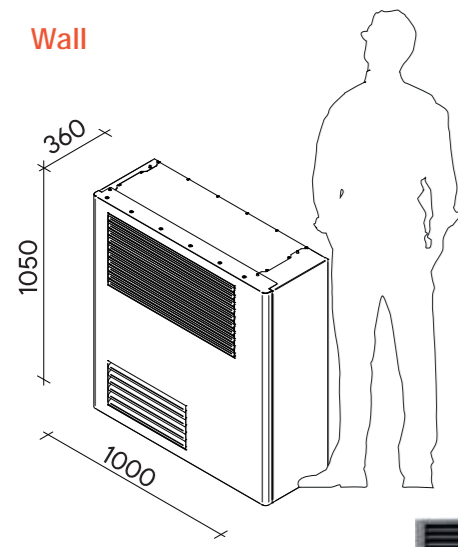

**MEVO SMART**

Heating Conditions – UNI EN 14511		
Heating Capacity A7/A20	kW	6.11
COP A7/A20		6.10
Heating Capacity A2/A20	kW	6.12
COP A2/A20		4.96
Heating Capacity A-7/A20	kW	5.02
COP A-7/A20		4.13
Cooling Conditions – UNI EN 14511		
Cooling Capacity A35/A27	kW	6.60
EER A35/W7		6.23
Low Temperature Conditions – UNI EN 14825		
		Average Climate
SCOP		4.59
SEER		6.84
Energy Label		A+++
General Data		
Power Supply		Single-phase
Refrigerant Type		R454C
Maximum Power Input	kW	2.00
Compressors		1x - Twin Rotary BLDC - modulation 20-100%
Inverter		1
Indoor Unit Sound Power Level IDX3* – UNI EN 12102	dB (A)	65
Indoor Unit Sound Power Level IDX4* – UNI EN 12103	dB (A)	66
Outdoor Unit Sound Power Level – UNI EN 12102	dB (A)	58
Weight	Kg	100

Wall



Recessed

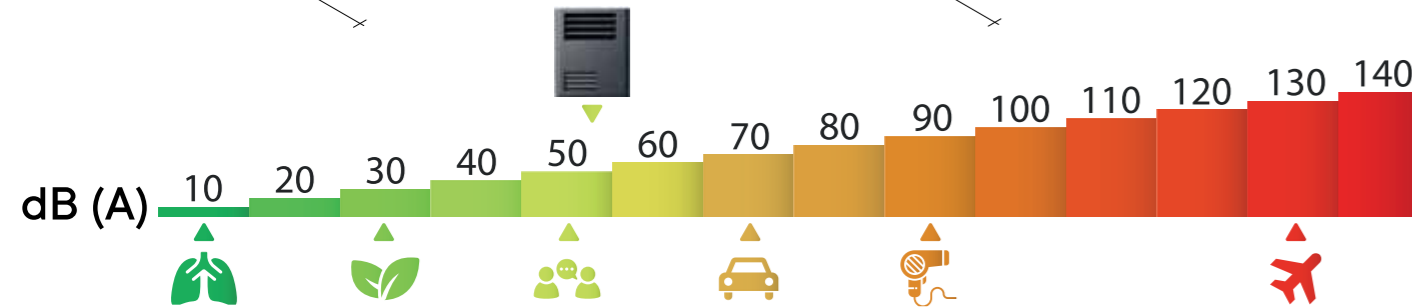
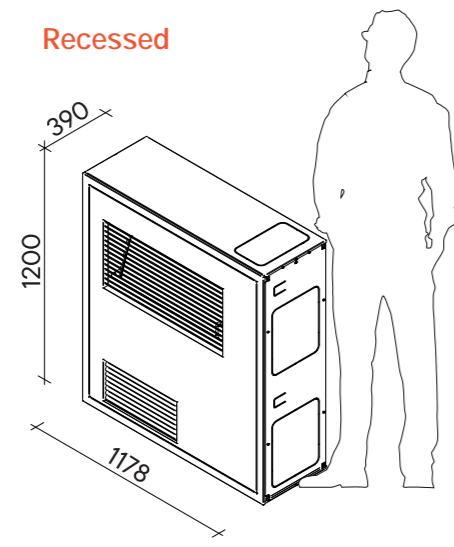

MEVO SMART

MK-DPCMSMT002  
DC.260430



**MEVO SMART**

The aesthetic revolution  
of heat pumps



Via dell'Artigianato, 44 - 31047  
Ponte di Piave (TV)  
Tel: 0422 289828  
info@gsicontrol.it  
www.gsicontrol.it

G.S.I. srl assumes no responsibility for any errors contained in this brochure and reserves the right to modify the specifications of its products without prior notice.





## THE SYNERGY BETWEEN TECHNOLOGY, DESIGN, AND INTEGRATION

MEVO SMART is an innovative system designed for high-efficiency apartments, small homes, offices, and shops. It combines a split air-to-air heat pump with domestic hot water (DHW) production in a compact and intelligent all-in-one solution with a ductable indoor unit.

**Designed and manufactured in Italy.** MEVO SMART blends contemporary design with state-of-the-art technology and a low-impact refrigerant.

The ultra-compact outdoor unit can be wall-mounted or recessed into the facade, ensuring discreet architectural integration. The ductable direct-expansion indoor unit enables independent air distribution across different rooms. With optional arrangements, the system can be equipped with a hydronic module to connect to radiant floor or ceiling heating and cooling systems. MEVO SMART offers greater integration, easier installation, and increased design freedom without aesthetic compromises.

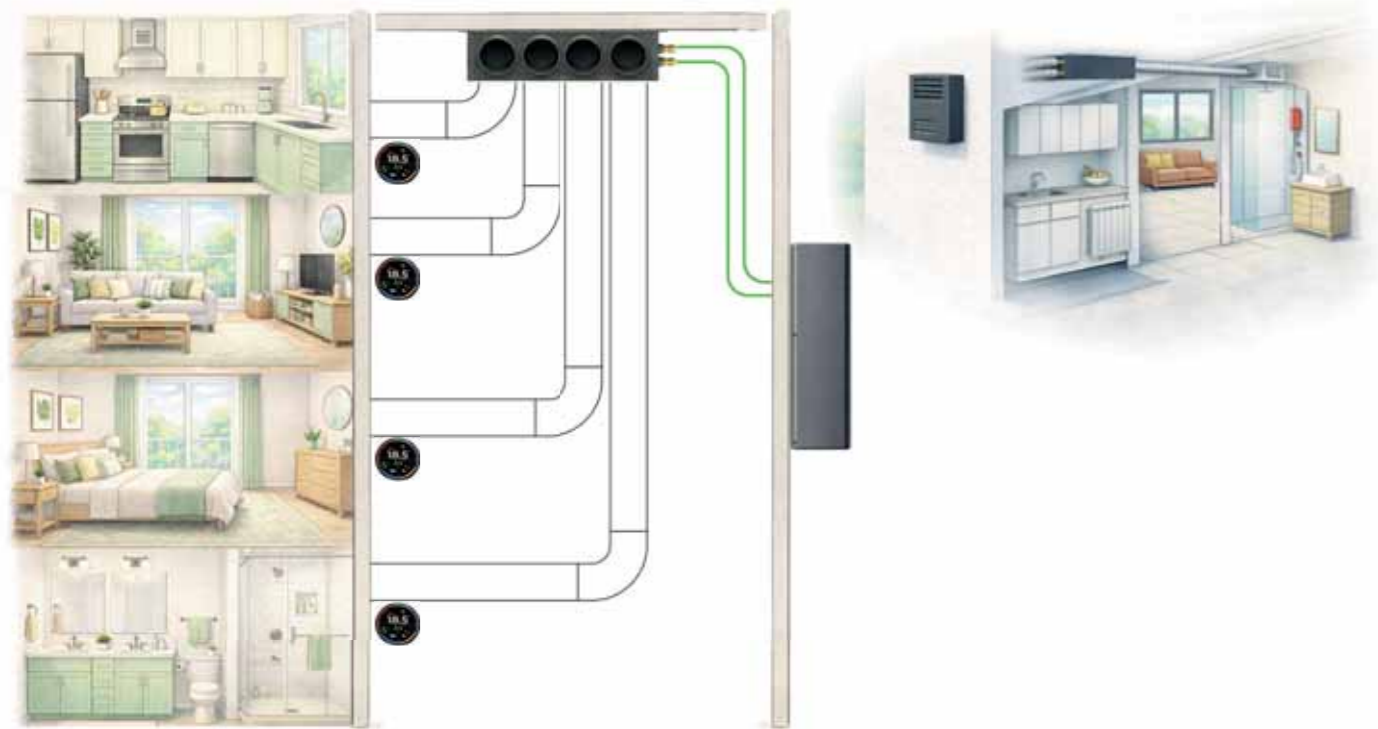

### COMPACT SYSTEM

At just 36 cm deep, MEVO SMART is among the most compact solutions in its category, delivering maximum efficiency with minimal footprint. The outdoor unit can be **wall-mounted or recessed** for seamless architectural

integration while keeping critical components accessible for service.

### HIGH EFFICIENCY ALL YEAR ROUND

MEVO SMART delivers comfort in every season. The R454C refrigerant (GWP 146) combines high performance with reduced environmental impact, maintaining efficiency even in demanding climates in both heating and cooling.

### INSTALLATION QUICK AND EASY

Installation of the piping between indoor and outdoor units is simple, as any split system. Hydraulic connections to the TWINSAN DHW module are made with threaded joints. The DHW storage module can be installed indoors or outdoors, depending on the project layout.



## DOMESTIC HOT WATER ALWAYS AVAILABLE

TWINSAN is a stainless-steel DHW module designed for integration with MEVO SMART, ensuring reliable, continuous domestic hot water production. Suitable for outdoor installation or recessed mounting, it adapts easily to any system layout.

It integrates two 70-liter **stainless-steel** tanks in a depth of just 36 cm, making it ideal for compact technical spaces and concealed installations. A large-surface heat exchanger and intelligent temperature management enable rapid charging and DHW production up to 70 °C. The unit is also ready to run anti-legionella cycles and is delivered as a complete, ready-to-use module, including all accessories required for commissioning and operation.



### OUTDOOR UNIT

Quiet and efficient, with a 3-blade fan and a robust structure designed for safe outdoor operation. The ultra-slim **"zero rear clearance"** design, with front air intake and discharge, **allows installation even in direct contact with the wall.**

### INDOOR UNIT

Discreet and efficient ducted unit capable of **managing up to 4 independent zones via dedicated radial fans.** Each room regulates temperature and airflow through its dedicated thermo-humidistat, ensuring tailored comfort and optimized consumption.

Thermo-humidistats with color touch controls and Wi-Fi mesh enable simple, reliable management throughout the home.

### TOTAL INTEGRATION

MEVO SMART integrates seamlessly into any environment: it can be recessed, installed within a planter module, and customized in color to perfectly match the building. The aesthetic panel is supplied directly by GSI for a clean, refined, compromise-free result: a system that is visible only when you want it to be.

## THE EXPANSION THAT MAKES THE DIFFERENCE

MEVO SMART, as a direct-expansion solution, provides simple and efficient air conditioning; with a dedicated module, it can also serve hydronic radiant floor or ceiling systems.

One machine, two operating modes: air and water. Direct expansion delivers speed and practicality, while radiant systems provide uniform comfort, giving engineers maximum flexibility and adaptability.



## ADVANCED SUPERVISION AND CONTROL

All GSI heat pumps and control systems are ready for Internet-connected remote management and supervision. The GSI CLOUD platform stores up to 13 months of operating data, enabling analysis, diagnostics, and performance optimization over time, supporting facility managers and service teams.

GSI CLOUD provides a configurable dashboard with a clear view of key variables and trends, simplifying troubleshooting and planned maintenance.



## INTUITIVE MANAGEMENT

The product **web app**, paired with **GSI's KlySense app**, enables clear and intuitive monitoring and control of the system from a computer, tablet, or smartphone. An end-user menu covers everyday comfort, while a password-protected service menu provides advanced parameters for configuration and technical management.

Users can set independent temperatures and schedules for each zone. The service menu includes a guided start-up wizard that simplifies installation and commissioning, reducing start-up time and limiting errors.

## EXPLORE THE FULL RANGE AND FIND THE SOLUTION THAT FITS YOUR NEEDS



**MEVO Standard**  
Single service operation: space heating or DHW, no system modification.



**MEVO Magis**  
Simultaneous heating and DHW, no system modification.